

PLEASE READ OUR INSTALLATION INSTRUCTIONS VERY CAREFULLY

Installation Instructions for the TUEX INVISI-SENSOR® DS 58.10.42677

Working description: The TUEX INVISI-SENSOR® is an active motion detector. The TUEX INVISI-SENSOR® emits a high frequency electro-magnetic (5.8 GHz) of very low energy (<10 mW) wave and receives its echo. The TUEX INVISI-SENSOR® detects the change in echo from even the slightest movement in the detection zone. The microprocessor then triggers the "switch ON" command.

NOTE: The TUEX INVISI-SENSOR® will detect movements through doors, panes of glass and thin walls.

Specifications of the TUEX INVISI-SENSOR®

Power supply	220-240 Volt <input type="checkbox"/> 100-130 Volt <input type="checkbox"/>
Power frequency	50/60 Hz
Internal Protection	IP 20
HF system	5.8 GHz CW ISM band
Transmission power:	<10mW
Rated inductive load:	for 220-240 Volt types: 200 VA for 100-130 Volt types: 100 VA
Adjustable reach:	between 3 and 10 m radius
Detection angle	360° in front of the TUEX sensor
Time setting	from 8 seconds to 12 minutes
Light control	from 2~2000 LUX
Power consumption:	approx.0.9W (in rest situation)

How to connect the TUEX INVISI-SENSOR®

N= neutral L= power line L'= switch wire
Connect the mains to: N and L
Connect the load to: N and L'

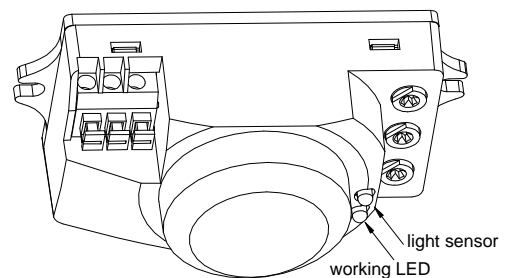
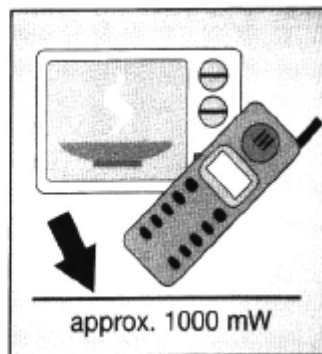
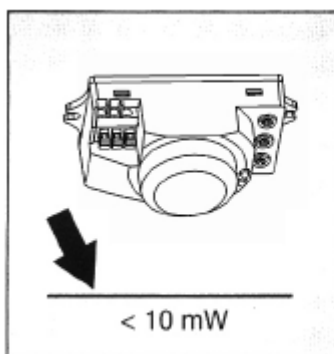
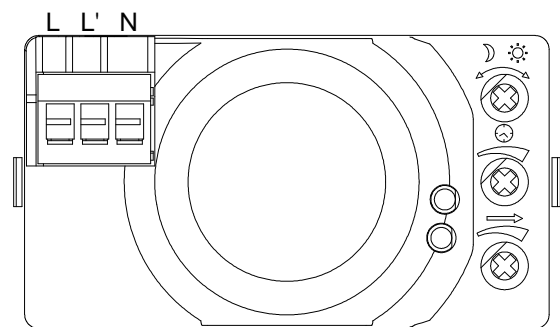

NOTE: the high frequency output of the TUEX INVISI-SENSOR® is <10 Mw- that is just one 100th of the transmission power of a mobile phone or the output of a microwave oven.

Important: persons or objects moving towards the TUEX INVISI-SENSOR® are detected best

Reach setting (sensitivity) of the TUEX INVISI-SENSOR®

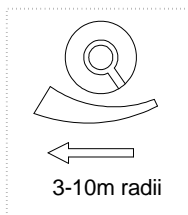

Reach is the term used to describe the radii of the more or less circular detection zone produced on the ground after mounting the sensor at a height of 2.5 m, turn the reach control fully anticlockwise to select minimum reach (approx.3 m radii), and fully clockwise to select maximum reach (approx. 10 m radii).

NOTE: the above detection distance is gained in the case of a person who is between 1.6 ~ 1.7 m tall with middle figure and moves at a speed of 1.0~1.5 m/sec. If person's stature, figure and moving speed change, the detection distance will also change.

Time setting of the TUEX INVISI-SENSOR®

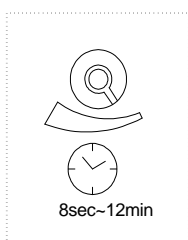

The sensor can be set to stay ON for any period of time between approx. 8 sec (turn fully anticlockwise) and a maximum of 12 min (turn fully clockwise). Any movement detected before this time elapse will re-start the timer. It is recommended to select the shortest time for adjusting the detection zone and for performing the walk test.

NOTE: after the load switches OFF, it takes approx. 1sec before it is able to start detecting movement again. The load will only switch on in response to movement once this period has elapsed.

Light-control setting of the TUEX INVISI-SENSOR®

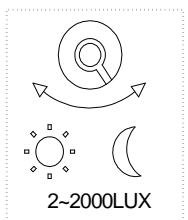

The chosen light response threshold can be infinitely from approx. 2-2000 LUX. Turn it fully anti-clockwise to select dusk- to-dawn operation at about 2 LUX. Turn it fully clockwise to select daylight operation at about 2000 LUX.

NOTE: The knob must be turned fully clockwise when adjusting the detection zone and performing the walk test in daylight.

Troubleshooting

Malfunction	Cause	Remedy
The load will not work	·Wrong light-control setting selected	·Adjust light level setting
	·Load faulty connected	·Check load connections
	·Main power is switched OFF	·Check of working LED lits
The load work always	·Continuous movement in the detection zone	·Check zone sensitivity setting
The load work without any identifiable movement	·The TUEX INVISI-SENSOR® is not mounted for on the right location	·Mount the TUEX INVISI-SENSOR® on a suitable location
	·Movement occurred, but not identified by the TUEX INVISI-SENSOR® (movement behind wall, movement of a small object in immediate load vicinity etc.)	·Check zone sensitivity setting
The load will not work despite visible movement	·Rapid movements are being suppressed to minimize malfunctioning or the detection zone you have set is too small	·Check zone sensitivity setting